

rineck
• Werkzeugtechnik



Inch & Metric



CAT-40 Shrink Tools

TOOLS ARE OUR PASSION  MADE IN GERMANY



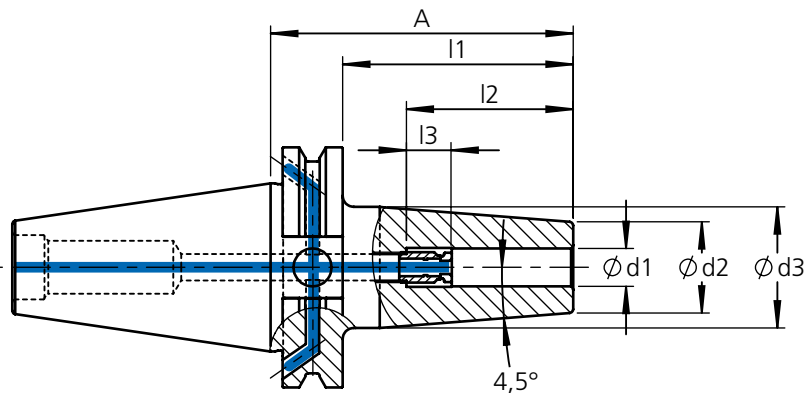

Shrink fit chuck CAT40 AD/B, standard execution 4,5° incl. length adjusting screw



order number	CAT	Ø d1	Ø d2	Ø d3	A	l1	l2	l3		
985Z-CAT40-3/4-A3.15	40	3/4	1.3	1.65	3.15	2.40	2.05	0.39	948-006	G2.5/18.000
985Z-CAT40-3/4-A4.72	40	3/4	1.3	1.65	4.72	3.97	2.05	0.39	948-006	
985Z-CAT40-3/4-A5.12	40	3/4	1.3	1.65	5.12	4.37	2.05	0.39	948-006	
985Z-CAT40-3/4-A6.30	40	3/4	1.3	1.65	6.30	5.55	2.05	0.39	948-006	
985Z-CAT40-7/8-A3.15	40	7/8	1.3	1.65	3.15	2.40	2.05	0.39	948-006	
985Z-CAT40-7/8-A4.72	40	7/8	1.3	1.65	4.72	3.97	2.05	0.39	948-006	
985Z-CAT40-7/8-A6.30	40	7/8	1.3	1.65	6.30	5.55	2.05	0.39	948-006	
985Z-CAT40-1-A3.94	40	1	1.73	2.05	3.94	3.19	2.28	0.39	948-006	
985Z-CAT40-1-A4.72	40	1	1.73	2.05	4.72	3.66	2.28	0.39	948-006	
985Z-CAT40-1-A5.12	40	1	1.73	2.05	5.12	4.37	2.28	0.39	948-006	
985Z-CAT40-1-A6.30	40	1	1.73	2.05	6.30	5.55	2.28	0.39	948-006	
985Z-CAT40-1 1/4-A3.94	40	1 1/4	1.73	2.05	3.94	3.19	2.44	0.39	948-006	
985Z-CAT40-1 1/4-A4.72	40	1 1/4	1.73	2.05	4.72	3.66	2.44	0.39	948-006	
985Z-CAT40-1 1/4-A6.30	40	1 1/4	1.73	2.05	6.30	5.55	2.44	0.39	948-006	

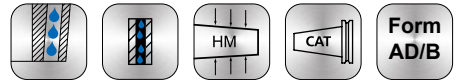
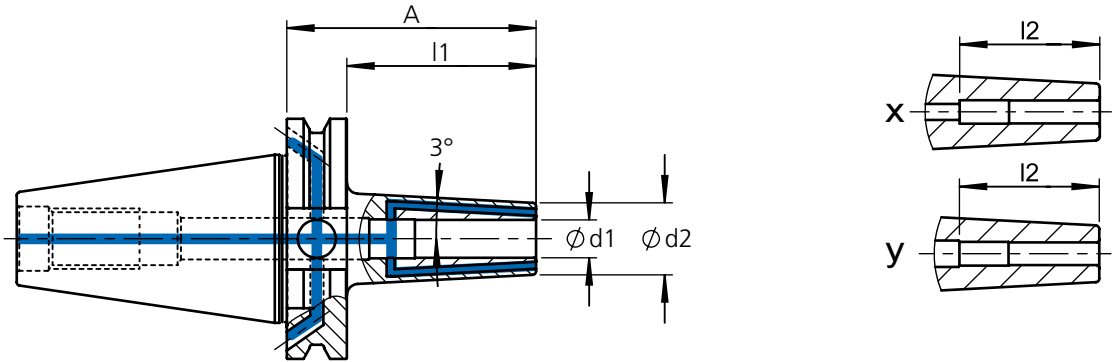

Shrink fit chuck CAT40 AD/B, slim execution 3° with 3 cooling jets Ø 0,05 inch

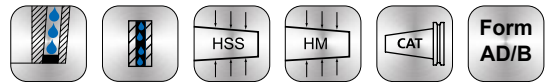
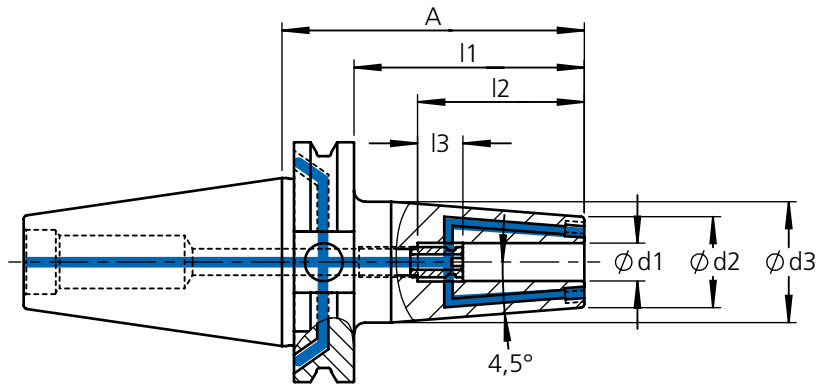

order number	CAT	Ø d1	Ø d2	Ø d3	A	l1	l2	x	y	
996Z-CAT40-1/8-2.95	40	1/8	0.43	-	3.70	2.95	0.47	-	x	G2.5/18.000
996Z-CAT40-1/8-3.94	40	1/8	0.43	-	4.69	3.94	0.47	-	x	
996Z-CAT40-3/16-2.95	40	3/16	0.51	-	3.70	2.95	0.63	-	x	
996Z-CAT40-3/16-3.94	40	3/16	0.51	-	4.69	3.94	0.63	-	x	
996Z-CAT40-1/4-2.95	40	1/4	0.59	-	3.70	2.95	1.42	-	x	
996Z-CAT40-1/4-3.94	40	1/4	0.59	-	4.69	3.94	1.42	-	x	
996Z-CAT40-5/16-2.95	40	5/16	0.67	-	3.70	2.95	1.42	-	x	
996Z-CAT40-5/16-3.94	40	5/16	0.67	-	4.69	3.94	1.42	-	x	
996Z-CAT40-3/8-2.95	40	3/8	0.75	-	3.70	2.95	1.65	-	x	
996Z-CAT40-3/8-3.94	40	3/8	0.75	-	4.69	3.94	1.65	-	x	

Shrink fit chuck CAT40 AD/B, standard execution 4,5° with closeable cooling jets, incl. length adjusting screw





order number	CAT	Ø d1	Ø d2	Ø d3	A	l1	l2	l3		
995Z-CAT40-1/8-A3.15	40	1/8	0.43	0.59	3.15	2.40	0.47	-	-	G2.5/18.000
995Z-CAT40-3/16-A3.15	40	3/16	0.55	0.87	3.15	2.40	0.63	-	-	
995Z-CAT40-1/4-A3.15	40	1/4	0.83	1.06	3.15	2.40	1.42	0.39	948-001	
995Z-CAT40-1/4-A4.72	40	1/4	0.83	1.06	4.72	3.97	1.42	0.39	948-001	
995Z-CAT40-5/16-A3.15	40	5/16	0.83	1.06	3.15	2.40	1.42	0.39	948-002	
995Z-CAT40-5/16-A4.72	40	5/16	0.83	1.06	4.72	3.97	1.42	0.39	948-002	
995Z-CAT40-3/8-A3.15	40	3/8	0.94	1.26	3.15	2.40	1.65	0.39	948-003	
995Z-CAT40-3/8-A4.72	40	3/8	0.94	1.26	4.72	3.97	1.65	0.39	948-003	
995Z-CAT40-7/16-A3.15	40	7/16	0.94	1.26	3.15	2.40	1.65	0.39	948-004	
995Z-CAT40-7/16-A4.72	40	7/16	0.94	1.26	4.72	3.97	1.65	0.39	948-004	
995Z-CAT40-1/2-A3.15	40	1/2	0.94	1.26	3.15	2.40	1.85	0.39	948-004	
995Z-CAT40-1/2-A4.72	40	1/2	0.94	1.26	4.72	3.97	1.85	0.39	948-004	
995Z-CAT40-5/8-A3.15	40	5/8	1.06	1.34	3.15	2.40	1.97	0.39	948-005	
995Z-CAT40-5/8-A4.72	40	5/8	1.06	1.34	4.72	3.97	1.97	0.39	948-005	
995Z-CAT40-3/4-A3.15	40	3/4	1.30	1.65	3.15	2.40	2.05	0.39	948-006	
995Z-CAT40-3/4-A4.72	40	3/4	1.30	1.65	4.72	3.97	2.05	0.39	948-006	
995Z-CAT40-7/8-A3.15	40	7/8	1.30	1.65	3.15	2.40	2.05	0.39	948-006	
995Z-CAT40-7/8-A4.72	40	7/8	1.30	1.65	4.72	3.97	2.05	0.39	948-006	
995Z-CAT40-1-A3.94	40	1	1.73	2.05	3.94	3.19	2.28	0.39	948-006	

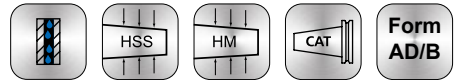
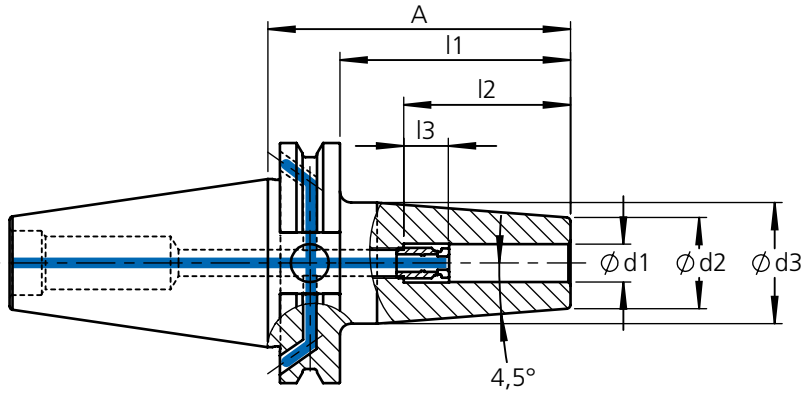

Shrink fit chuck CAT40 AD/B, standard execution 4,5° incl. length adjusting screw

METRIC All dimensions metric



order number	CAT	Ø d1	Ø d2	Ø d3	A	l1	l2	l3		
985 - CAT4006A80	40	6	21	27	80	60.9	36	10	948-001	G2.5/18.000
985 - CAT4006A120	40	6	21	27	120	100.9	36	10	948-001	
985 - CAT4006A130	40	6	21	27	130	110.9	36	10	948-001	
985 - CAT4008A80	40	8	21	27	80	60.9	36	10	948-002	
985 - CAT4008A120	40	8	21	27	120	100.9	36	10	948-002	
985 - CAT4008A130	40	8	21	27	130	110.9	36	10	948-002	
985 - CAT4010A80	40	10	24	32	80	60.9	41	10	948-003	
985 - CAT4010A120	40	10	24	32	120	100.9	41	10	948-003	
985 - CAT4010A130	40	10	24	32	130	110.9	41	10	948-003	
985 - CAT4012A80	40	12	24	32	80	60.9	47	10	948-004	
985 - CAT4012A120	40	12	24	32	120	100.9	47	10	948-004	
985 - CAT4012A130	40	12	24	32	130	110.9	47	10	948-004	
985 - CAT4016A80	40	16	27	34	80	60.9	50	10	948-005	
985 - CAT4016A120	40	16	27	34	120	100.9	50	10	948-005	
985 - CAT4016A130	40	16	27	34	130	110.9	50	10	948-005	
985 - CAT4020A80	40	20	33	42	80	60.9	52	10	948-006	
985 - CAT4020A120	40	20	33	42	120	100.9	52	10	948-006	
985 - CAT4020A130	40	20	33	42	130	110.9	52	10	948-006	
985 - CAT4025A100	40	25	44	53	100	80.9	58	10	948-006	
985 - CAT4025A130	40	25	44	53	130	110.9	58	10	948-006	
985 - CAT4032A100	40	32	44	53	100	80.9	62	10	948-006	



www.rineck.de

rineck

• Werkzeugtechnik

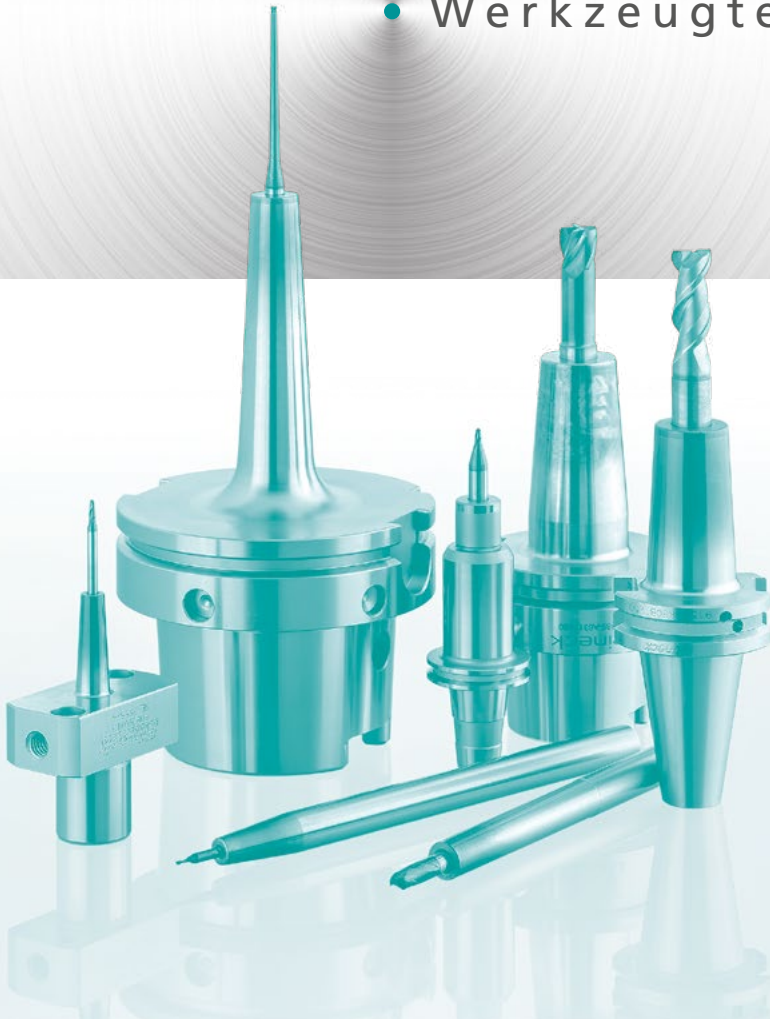

TYSON TOOL®

TYSON TOOL COMPANY LIMITED
75 Ormont Drive, Toronto, ON. M9L-2S3
Tel: (416) 746-3688 -- Fax: (416) 746-5415
www.tysonstool.com -- sales@tysonstool.com

Available From