

rineck
• Werkzeugtechnik



Inch & Metric



HSK-F80 Makino MAG

TOOLS ARE OUR PASSION  MADE IN GERMANY

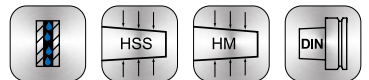
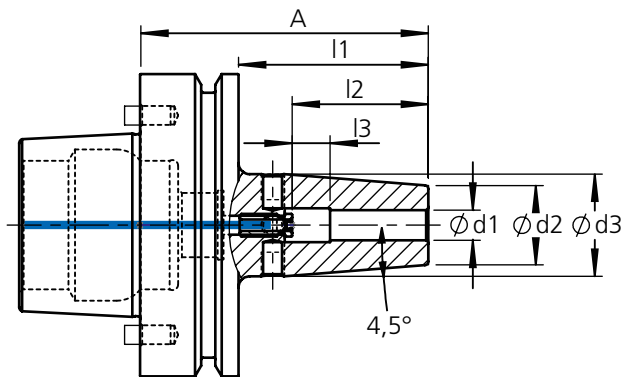
Shrink fit chuck HSK-F80 Makino with thread for coolant tube, standard execution 4,5° M6 bores for balancing screws, 2-pin Makino version



-69 893-6

Bestell-Nr. order number No.	HSK	Ø d1	Ø d2	Ø d3	A	l1	l2	l3		
985Z-F80M-1/4-A3.00	F80M	1/4	0.83	1.06	3.00	1.98	1.42	0.39	948-001	G2.5/33.000 or U<1gmm
985Z-F80M-5/16-A3.00	F80M	5/16	0.83	1.06	3.00	1.98	1.42	0.39	948-002	
985Z-F80M-3/8-A3.00	F80M	3/8	1.00	1.22	3.00	1.98	1.69	-	-	
985Z-F80M-7/16-A3.00	F80M	7/16	1.02	1.26	3.00	1.98	1.69	-	-	
985Z-F80M-1/2-A3.00	F80M	1/2	1.02	1.30	3.00	1.98	1.89	-	-	
985Z-F80M-1/2-A6.00	F80M	1/2	1.02	1.30	6.00	4.98	1.89	0.39	948-004	
985Z-F80M-5/8-A3.00	F80M	5/8	1.14	1.42	3.00	1.98	2.01	-	-	
985Z-F80M-3/4-A2.75	F80M	3/4	1.38	-	2.75	1.73	1.59	-	-	
985Z-F80M-3/4-A3.00	F80M	3/4	1.40	1.61	3.00	1.98	2.01	-	-	
985Z-F80M-3/4-A4.00	F80M	3/4	1.40	1.61	4.00	2.98	2.01	0.39	948-006	
985Z-F80M-1-A2.75	F80M	1	1.81	-	2.75	1.73	1.73	-	-	
985Z-F80M-1-A3.00	F80M	1	1.83	2.05	3.00	1.98	1.93	-	-	
985Z-F80M-1-A6.30	F80M	1	1.72	2.08	6.30	5.28	1.93	0.39	948-006	
985Z-F80M-1 1/4-A3.50	F80M	1 1/4	1.77	2.09	3.50	2.48	2.56	-	-	

www.rineck.de

rineck

• Werkzeugtechnik

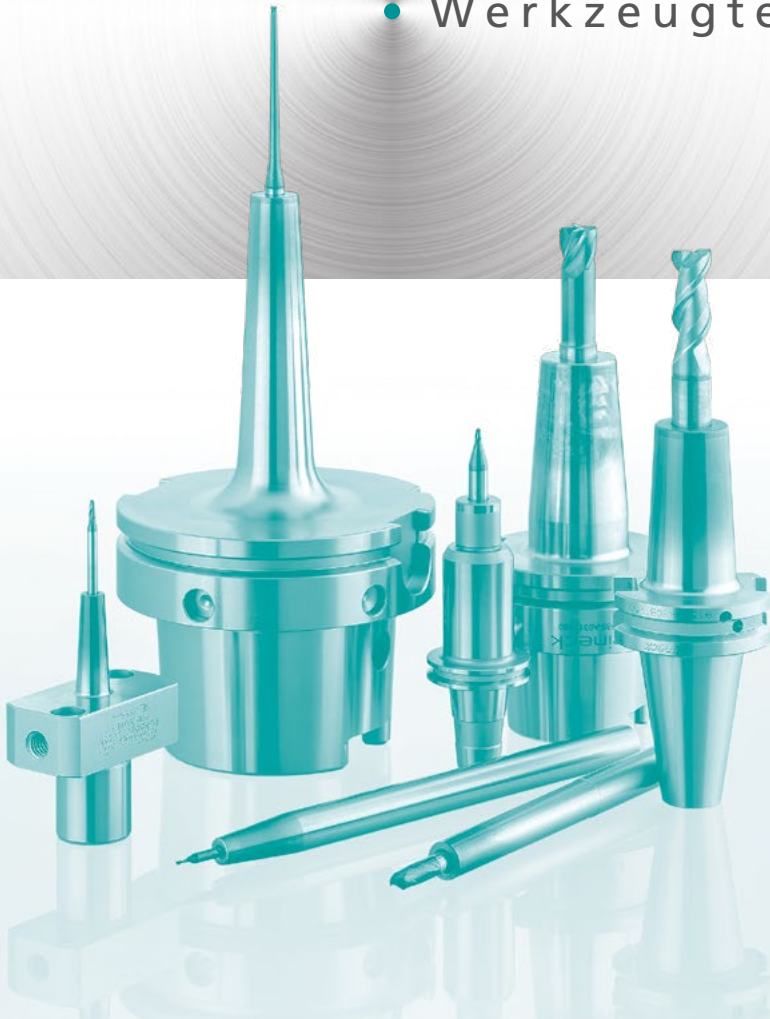

TYSON TOOL®

TYSON TOOL COMPANY LIMITED
75 Ormont Drive, Toronto, ON. M9L-2S3
Tel: (416) 746-3688 -- Fax: (416) 746-5415
www.tysonstool.com -- sales@tysonstool.com

Available From